

Amarillo Series Fan Drive

Model A32

Amarillo Gear Company LLC reserves the right to make design modifications to our gear drives that may change the given dimensions. The dimensions shown in this document may not exactly reflect the dimensions of gear drives currently being offered. Request a *certified dimension print* for construction use.

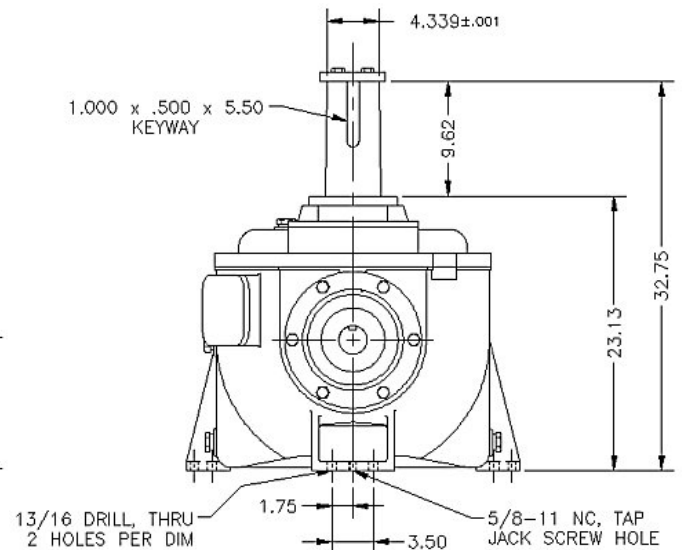
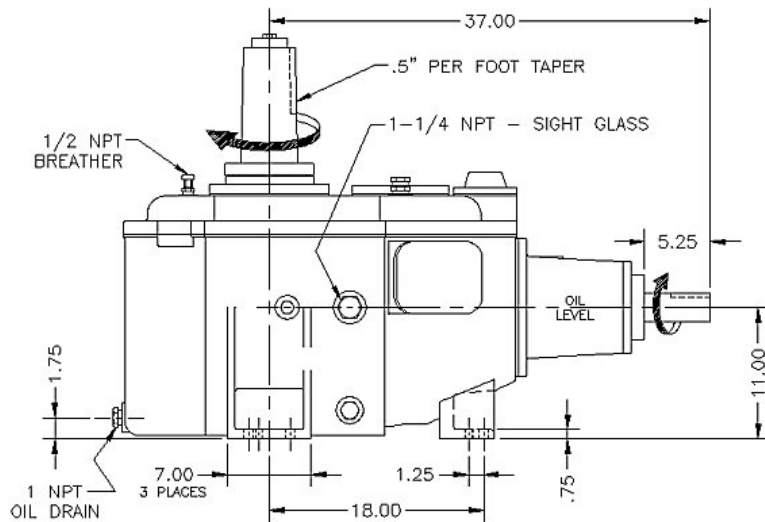
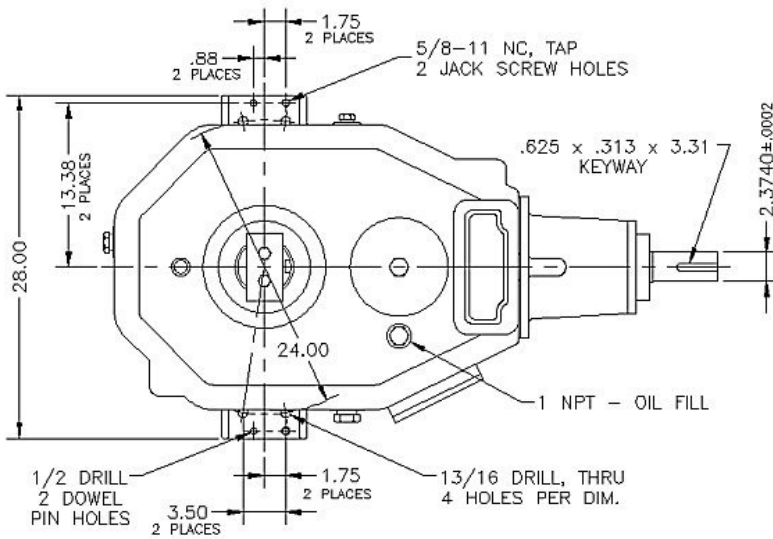

SERVICE HORSEPOWER RATINGS (2.0 SERVICE FACTOR)

Input (RPM)	Nominal Ratio					
	6.47	7.89	8.80	10.16	11.18	12.93
1750	160	160	160	160	160	160

OIL TYPE: _____ ISO 220 / AGMA 5 or 5S / No EP additives
 OIL CAPACITY: _____ 17 gallons (64 L)
 WEIGHT, DOMESTIC SHIPPING: _____ 1575 lbs.
 WEIGHT, EXPORT SHIPPING w/EXPORT BOX: _____ 1720 lbs.
 EXPORT BOX DIMENSIONS (L x W x H): _____ 55 x 36 x 40 (inches)

Amarillo Gear Company can provide a matching output shaft when necessary. A shaft drawing or schematic information will be necessary. See catalog for further details.