

# PARALLEL SHAFT GEAR DRIVES

FOR DRY COOLING SYSTEMS  
AND STEAM CONDENSERS

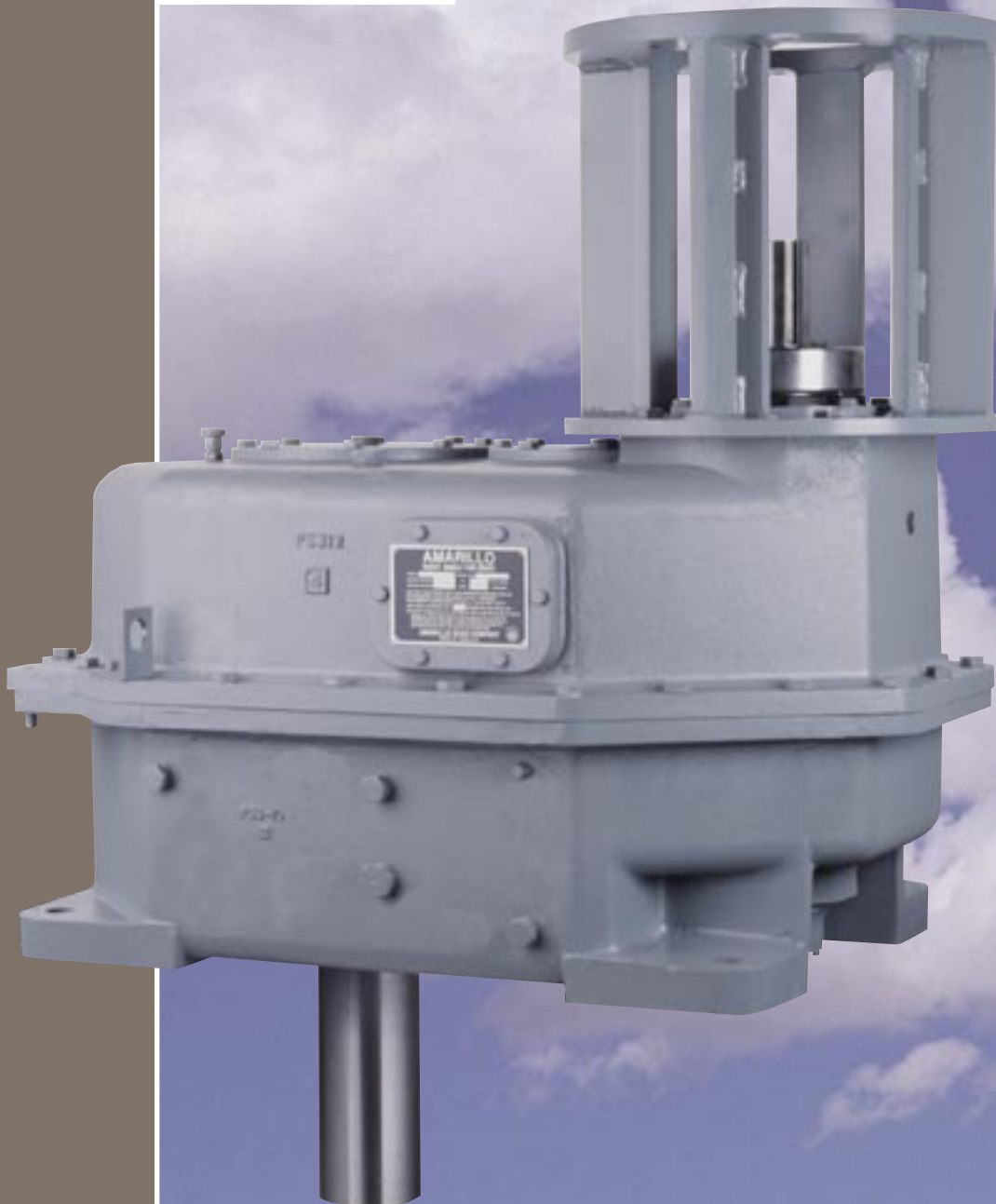

Amarillo<sup>®</sup>  
Gear  
Company



## Parallel Shaft Gear Drive Selection

Having a gear drive specifically designed for dry cooling systems and steam condensers means the process for selecting the correct gear drive is simple. It's as easy as following the 5 steps shown below. For unusual applications or extreme operating conditions, contact Amarillo Gear Company's Engineering Department for help making the correct selection.

1. Calculate the required ratio by dividing the motor speed (input) by the fan speed (output).
2. Select a gear drive from Table I or II that has a power rating, under the required ratio column, that is equal to or greater than the motor power at the motor speed. Use Table I for Horsepower ratings and Table II for Kilowatt ratings. All ratings include a 2.0 service factor recommended by Amarillo Gear Company for gear drives used in cooling tower fan service.

**Table I - Service Power Ratings (Service Factor = 2.0)**

		HORSEPOWER																	
Model	Input RPM	Ratio																	
		8	9	10	11	12	13	14	15	16	17	18	19	20	21	22	23	24	25
P2175	1750	300	266	243	216	203	190	175	163	150	140	130	125	120	116	112	108	104	100
	1450	250	221	202	180	169	158	145	135	125	116	108	104	100	96	93	90	86	83
	1160	203	180	164	146	137	128	118	110	101	95	88	84	81	78	76	73	70	68
P2195	1750	373	341	318	291	272	255	243	231	215	207	197	187	180	177	169	167	156	149
	1450	320	293	273	250	233	219	209	198	185	177	169	160	154	149	141	140	130	124
	1160	267	244	228	208	194	182	174	165	155	145	141	131	125	120	114	113	105	100
P2225	1750			500	460	437	412	385	368	350	333	315	300	285	271	257	243	229	215
	1450			415	382	363	342	320	305	291	276	261	250	237	225	213	202	190	179
	1160			335	308	293	276	267	247	235	223	211	201	191	182	173	163	153	144

**Table II - Service Power Ratings (Service Factor = 2.0)**

		KILOWATTS																	
Model	Input RPM	Ratio																	
		8	9	10	11	12	13	14	15	16	17	18	19	20	21	22	23	24	25
P2175	1750	224	198	181	161	151	142	130	122	112	104	97	93	89	87	84	81	78	75
	1450	186	165	151	134	126	118	108	101	93	87	81	78	75	72	69	67	64	62
	1160	151	134	122	109	102	95	88	82	75	71	66	63	60	58	57	54	52	51
P2195	1750	278	254	237	217	203	190	181	172	160	154	147	139	134	132	126	125	116	111
	1450	239	218	204	186	174	163	156	148	138	132	126	119	115	111	105	104	97	92
	1160	199	182	170	155	145	136	130	123	116	108	105	98	93	89	85	84	78	75
P2225	1750			373	343	326	307	287	274	261	248	235	224	213	202	192	181	171	160
	1450			309	285	271	255	239	227	217	206	195	186	177	168	159	151	142	133
	1160			250	230	218	206	199	184	175	166	157	150	142	136	129	122	114	107

3. Use the exact ratio found in Table III, to compute your actual fan speed. All ratios are within 2% of the nominal ratio.

**Table III - Exact Ratios**

		Exact Ratios																	
Model		8	9	10	11	12	13	14	15	16	17	18	19	20	21	22	23	24	25
P2175		7.97	9.13	9.92	11.10	11.84	13.03	13.81	14.73	16.21	16.73	17.86	18.91	20.32	20.81	22.22	23.26	23.53	25.28
P2195		7.95	8.93	9.96	11.18	12.00	13.03	13.82	15.03	16.12	17.31	18.01	19.29	20.31	21.10	22.33	22.56	24.16	25.43
P2225				9.88	10.91	11.97	12.80	14.01	15.08	16.06	17.16	18.22	19.37	19.75	20.63	22.03	22.33	23.87	25.36

4. The down thrust capacity of Amarillo Parallel Shaft Drives exceeds the requirements for most applications. If the total of the fan weight and fan thrust is greater than shown in Table IV, other bearing selections are available. Contact Amarillo Gear Company's Engineering Department for information.

**Table IV - Vertical Down Thrust Capacity**

Model	Thrust lb <sub>f</sub>	Thrust kN
P2175	6000	26.7
P2195	9100	40.5
P2225	15000	66.7

5. Amarillo Parallel Shaft Drives are designed to ensure that the thermal rating meets or exceeds the service rating in Tables I and II when the ambient temperature is 120°F or less. No thermal calculations are required. For rare applications where the ambient temperature is above 120°F, contact Amarillo Gear Company's Engineering Department for thermal ratings for your specific project conditions.

## PARALLEL SHAFT DIMENSIONS

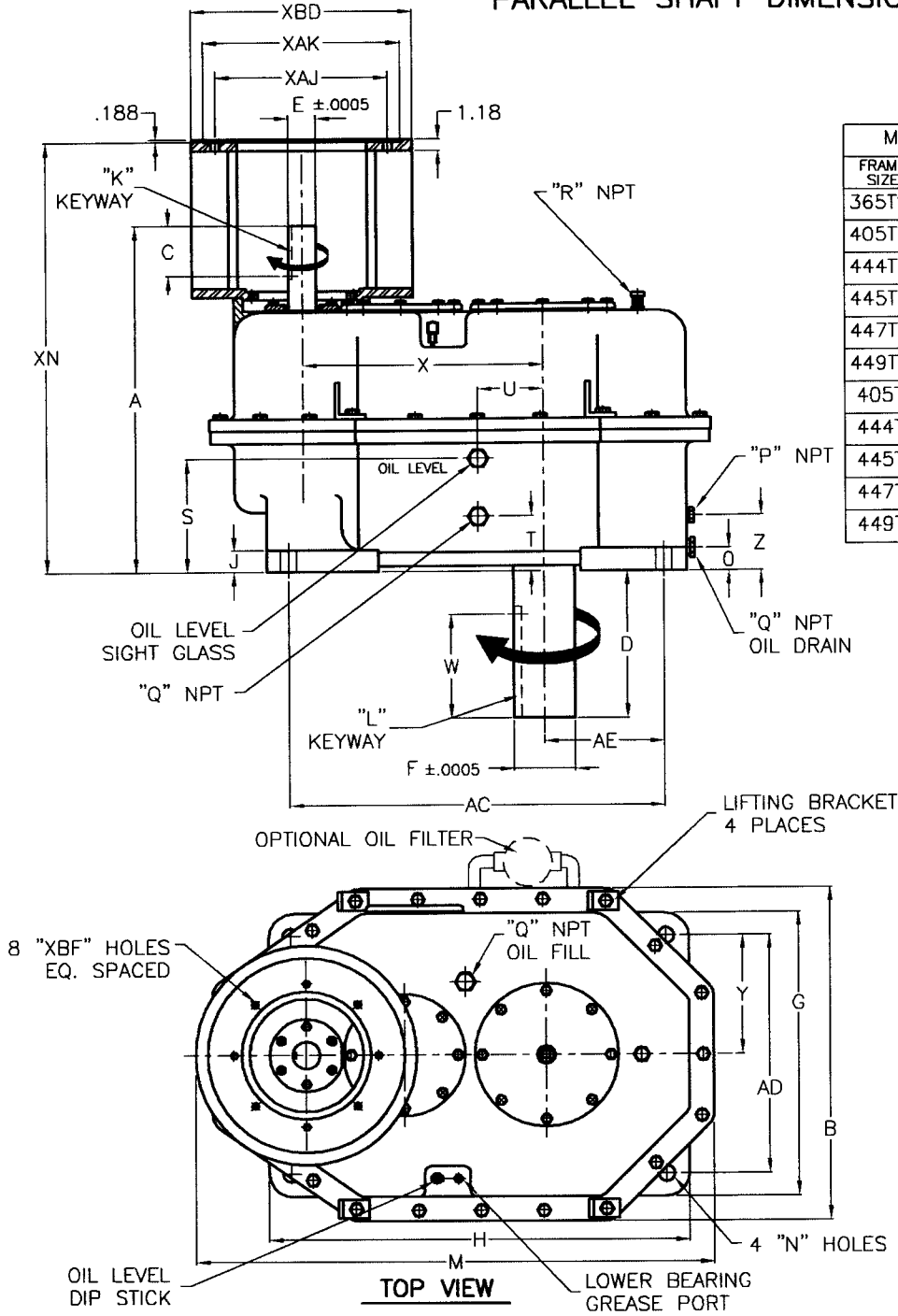

MOTOR MOUNT DIMENSIONS (INCH)					
FRAME SIZE	XAJ	XAK	XBD	XBF	XN
365TSC	11	12.5	14	1 <sup>1</sup> / <sub>16</sub>	"A"+ 3.75
405TSC	11	12.5	14	1 <sup>1</sup> / <sub>16</sub>	"A"+ 4.25
444TSC	14	16	18	1 <sup>1</sup> / <sub>16</sub>	"A"+ 4.75
445TSC	14	16	18	1 <sup>1</sup> / <sub>16</sub>	"A"+ 4.75
447TSC	14	16	18	1 <sup>1</sup> / <sub>16</sub>	"A"+ 4.75
449TSC	14	16	18	1 <sup>1</sup> / <sub>16</sub>	"A"+ 4.75
405TC	11	12.5	14	1 <sup>1</sup> / <sub>16</sub>	"A"+ 7.25
444TC	14	16	18	1 <sup>1</sup> / <sub>16</sub>	"A"+ 8.50
445TC	14	16	18	1 <sup>1</sup> / <sub>16</sub>	"A"+ 8.50
447TC	14	16	18	1 <sup>1</sup> / <sub>16</sub>	"A"+ 8.50
449TC	14	16	18	1 <sup>1</sup> / <sub>16</sub>	"A"+ 8.50

**TABLE IV – DIMENSIONS (INCH)**

MODEL	A	B	C	D <sup>1</sup>	E	F		G	H	J	K	L	M <sup>2</sup>	N	O
						STD	EXT. BRG. HOUSING								
P2175	28.75	25.25	3.75	NOTE 1	1.8740	4.1240	3.9990	21.25	32.00	1.88	1/2 X 1/4	1 X 1/2	39.00	1 <sup>5</sup> / <sub>16</sub>	1.88
P2195	30.50	27.25	4.25	NOTE 1	2.2490	4.6240	4.4990	23.25	34.31	1.88	1/2 X 1/4	1 1/4 X 5/8	42.25	1 <sup>5</sup> / <sub>16</sub>	1.88
P2225	33.75	30.50	5.00	NOTE 1	2.9360	5.4990	5.3740	26.25	38.75	2.13	3/4 X 3/8	1 1/4 X 5/8	47.00	1 <sup>9</sup> / <sub>16</sub>	2.13

MODEL	P	Q	R	S	T	U	V	W	X	Y	Z	AB	AC	AD	AE	WEIGHT (LB)
P2175	3/4	1	1/2	9.00	4.00	5.00	16.75	8.00	17.625	9.00	4.00	10.75	29.50	18.00	9.13	1600
P2195	3/4	1	1/2	9.25	4.50	5.38	18.75	8.00	19.625	9.75	4.50	11.75	30.63	19.50	9.75	2200
P2225	3/4	1	1/2	9.75	5.00	6.00	20.75	9.00	22.688	11.50	5.00	13.00	35.00	23.00	11.25	3800

**NOTES:**

1. TO SUIT CUSTOMER SPECIFICATIONS. FOR "D" LENGTHS EXCEEDING 30", THE EXTENDED BEARING HOUSING IS REQUIRED.
2. FOR XBD= 18"
3. ALL DIMENSIONS IN INCHES. CONTACT FACTORY FOR METRIC DIMENSION PRINTS.

# FEATURES

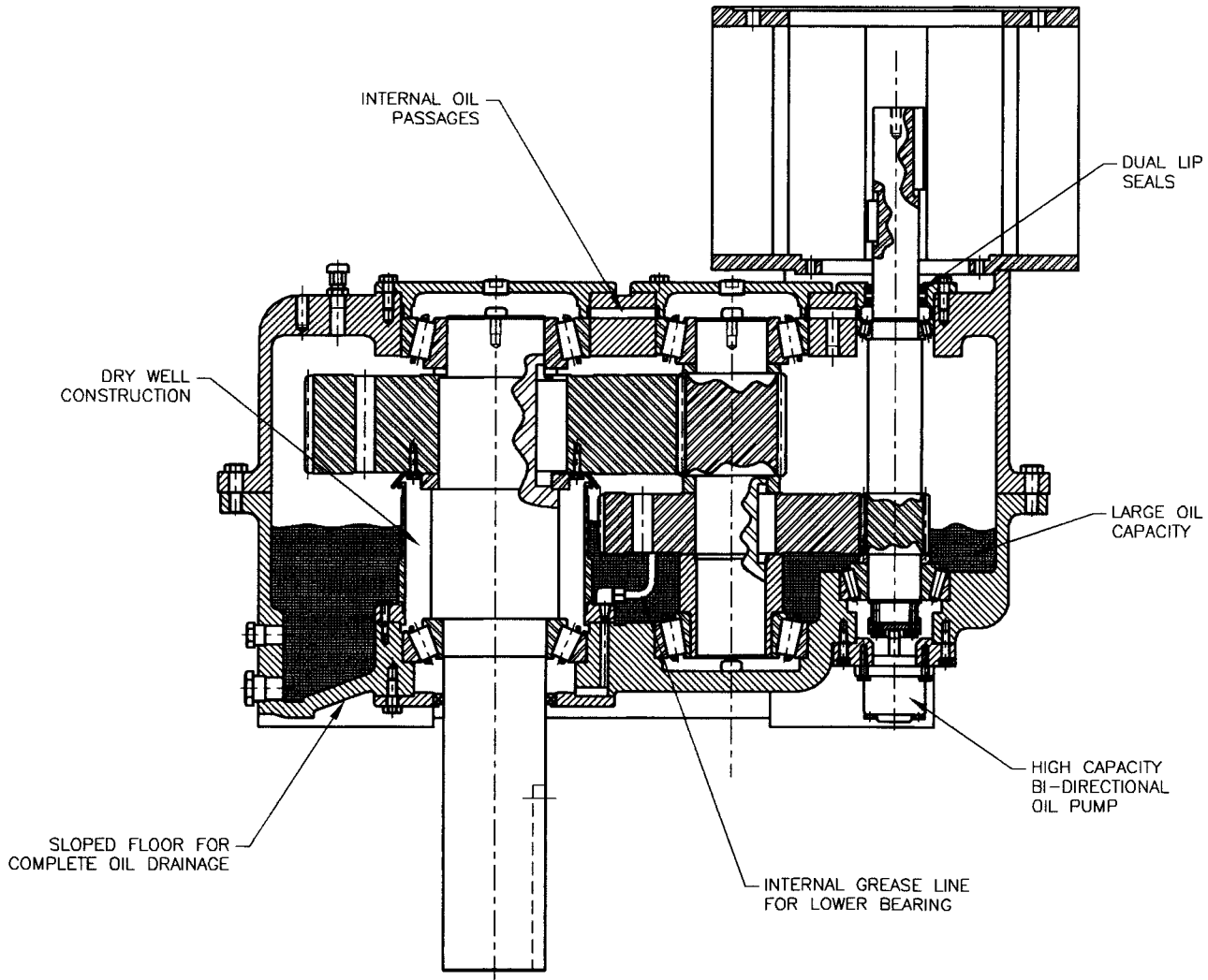
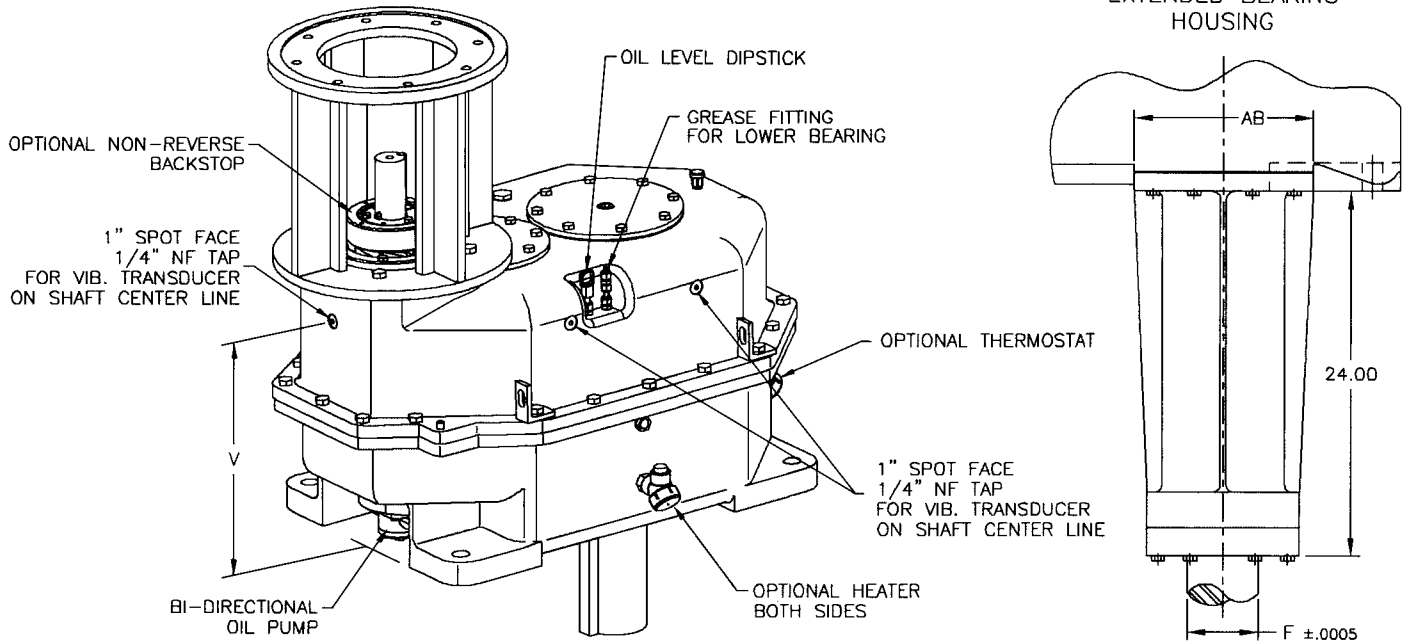

Each Amarillo Gear Company fan drive is designed and manufactured specifically for the demanding environment of dry cooling systems and steam condensers. As with any precision machine component, proper selection, installation, maintenance and operating procedures are imperative for long life and trouble-free service. Our engineers will be pleased to assist when unusual conditions require special procedures.

### Ratio

All ratios are reducing and defined as the ratio of input speed to output speed. Nominal reduction ratios shown in Tables I & II are exact within  $\pm 2\%$ . Exact ratios are shown in Table III.

### Ratings

Amarillo Gear Company recommends a minimum service factor of 2.0 for gear drives in cooling tower fan service when driven by electric motors. All ratings in Tables I & II are service ratings and include a 2.0 service factor. Ratings are listed for both 60 and 50 cycle electric motor speeds. Ratings at intermediate speeds may be interpolated from the tables. Contact the factory for recommendations when the driver speed exceeds 1800 rpm.

### Thermal Rating

By designing specifically for dry cooling system and steam condenser service, Amarillo Gear engineers ensured that the thermal ratings equal or exceed the service ratings listed in Tables I & II when the ambient air temperature is 120°F or less.

Contact the factory for thermal rating when the air temperature exceeds 120°F.

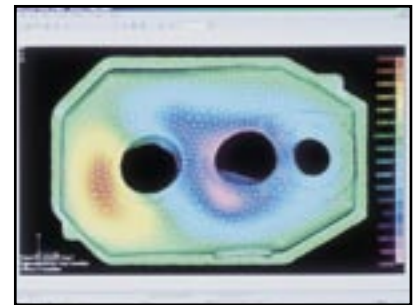

### Selection

The required ratio is established by dividing the input or driver speed by the output or fan speed. Select the ratio from either Table I or II that is the closest to the required ratio. Select the model that has a service rating listed under the required ratio column that is equal to or greater than the power rating of the driver at the input speed. When the gear drives are to be selected using a service factor other than 2.0, multiply the "service rating" from the tables by 2.0 to get the "mechanical rating." The "mechanical rating" is then divided by the appropriate service factor to obtain the new "service rating" at the required conditions.

### Limited Warranty

The Amarillo Gear Company Parallel Shaft Gear Drive is guaranteed against defects in workmanship and material for a period of one year after installation when operated under normal service at rated capacity. Within the above stated period, the manufacturer will replace the defective parts returned transportation prepaid. The buyer shall not be entitled to incidental or consequential damages, losses or expenses. The guarantee will not apply to repairs made outside the factory without the consent of the manufacturer or to drives that have been subject to abuse, accident, neglect, or improper installation. No warranty is made in regard to bearings, trade accessories, machinery, or other articles of merchandise not manufactured by us. This warranty is expressly made in lieu of any warranties otherwise expressed or implied by law.

### Direction of Rotation

Normal rotation is both shafts clockwise, when viewed from the top, as shown in the illustration. Occasional use with both shafts rotating counterclockwise is permissible. Special bearing arrangements are used when the primary direction of rotation is counterclockwise, incurring additional cost, and the gear drives should be ordered accordingly.



# Parallel Shaft Gear Drives For Dry Cooling Systems and Steam Condensers

The gear drives Amarillo Gear Company produces for dry cooling systems and steam condensers reflect a long history of quality workmanship and reliability. Amarillo Gear has been designing and manufacturing right angle drives since 1934, and the commitment to excellence continues today. One example of this commitment is the availability of complete noise and vibration testing, with all data taken under full horsepower loading up to 500 hp.

Amarillo Gear drives also are made available for, and are commonly used with, many other applications. The basic design and inherent ruggedness of Amarillo Gear drives is adaptable to many types of vertical machines such as agitators, mixers, dryers and separators.

## Features

Design features and ratings are in accordance with, or exceed, the minimum requirements of AGMA (American Gear Manufacturers Association) and CTI (Cooling Technology Institute) standards.

### Housing and Castings

Casings are rigidly designed, using finite element analysis, and constructed to absorb internal and external loads with minimum deflection. Doweled gear case and cover assures permanent alignment of bearings and gears under load. The sloped floor of the gear case adds rigidity and permits complete drainage of oil. All casting materials are gray iron for effective damping of noise and vibration. All mating castings are sealed using "formed-in-place" gasket material which eliminates "weeping" associated with fiber-type gaskets. Each model has mounting provisions for easy installation of three accelerometers for vibration monitoring of each shaft. Mounting feet are pre-drilled with pilot holes to assist in installation of dowel pins.

### Helical Gears

Helical gears are designed specifically for fan drive service and are precision machined from nickel alloy steel, case hardened and precision ground to provide low-noise, low vibration operation.

### Quiet Operation

Quiet operation of the parallel shaft gear drive is achieved through careful design and controlled manufacturing methods of components. Our engineers understand all of the many parameters that effect gear noise and have applied the latest research to the design of the parallel shaft gear drive. Precision machined, ground gear teeth are crowned with the ideal amount of tip and root relief to ensure quiet operation. Rigid shafts and rigid, permanently aligned, housings guarantee precise alignment of gears under load. Test results collected in our state-of-the-art test facility prove that our sound levels are the lowest available in the industry.

### Bearings

All bearings are roller type, provided by major manufacturers. The fan shaft thrust bearing is designed to carry all loads imposed by the fan while maintaining 100,000 hours  $L_{10}$ . All bearings are sized to meet or exceed the minimum life requirements of AGMA and CTI.

### Shafting

Alloy steel output shafts are sized to provide a rugged spindle for the fan. Surfaces for gears, bearings, input coupling and fan hub are precision ground.

### Shaft Seals

The input shaft openings has dual spring-loaded, double-lipped type seals to keep outside contamination from entering the gearbox. The fan shaft is sealed using dry well construction with isolation protection using a lip seal. Amarillo Gear Company was an early pioneer in the use and perfection of this unique sealing arrangement which provides maximum protection against vertical shaft leakage.

### Non-reverse Backstop

Reverse rotation of the fan is prevented by adding our proprietary pin and ratchet non-reverse backstop to the fan drive. This reliable, no-maintenance, backstop has been successfully used on Amarillo Gear products for over 60 years. This external device can be ordered on new fan drives or installed easily on existing fan drives in the field.

### Lubrication

A positive displacement oil pump, driven by the input shaft, provides adequate lubrication in either direction or at any speed. The oil pump is protected between the front mounting feet to prevent accidental damage during handling. All plumbing is internal to the gear case, eliminating the risk of external oil leaks and handling damage. The grease line for the thrust bearing is internal to the gear case with an easily accessible grease fitting located on top of the gear drive. A dip stick and permanently mounted oil sight level gauge is provided on all units to provide direct visual determination of oil level.

### Service Openings

Large inspection plate facilitates periodic inspections. Ports for oil fill, oil drain and venting are tapped and located for installation of remote service piping when desired.

### Optional Features

Special shaft extensions, back stop (anti-windmilling), lubricating oil heaters, oil temperature gauges, oil level switch and other accessory items are available on special order.

**Catalog PS 4/01**



T.M.

# Amarillo® Gear Company