

RIGHT ANGLE GEAR DRIVES

“A” SERIES DRIVES FOR COOLING TOWERS



Single
Reduction



Double
Reduction



Amarillo®
Gear
Company



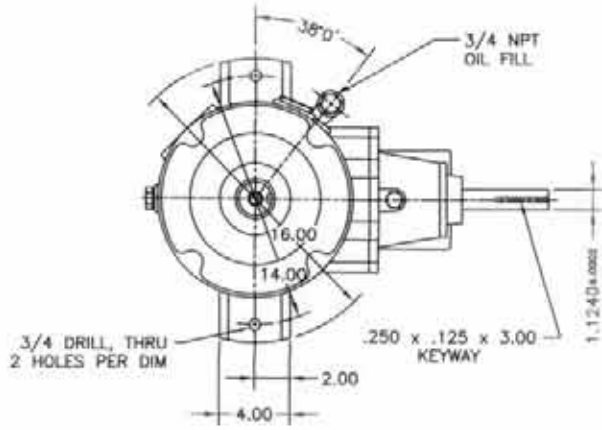

Model A20

Input RPM	Gear Ratio	Fan RPM	Service HP Rating (2.0 Service Factor)
1750	2.71	646	35
1750	3.27	535	35
1750	3.78	463	30
1750	4.11	426	25
1750	4.89	358	20

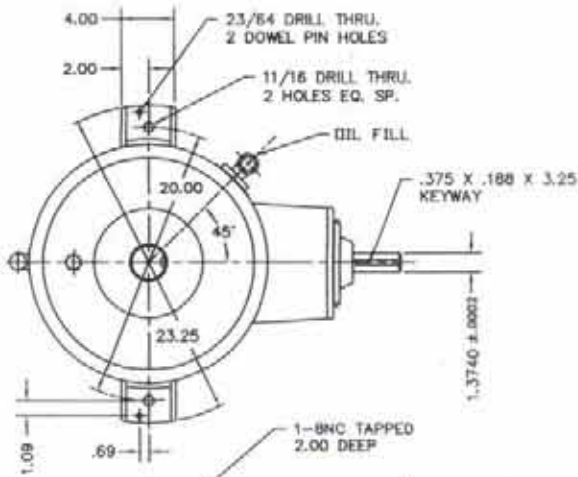
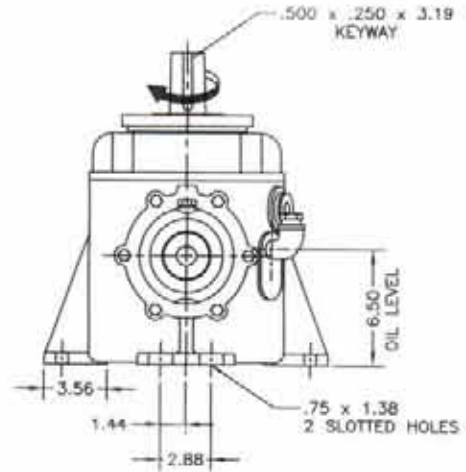
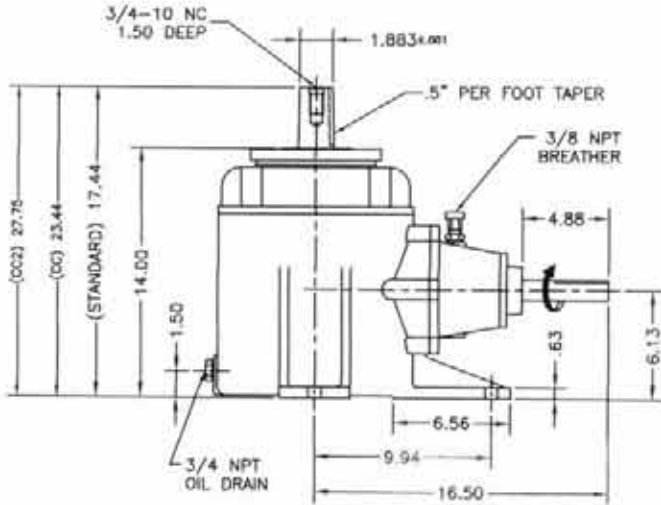

Model A22

Input RPM	Gear Ratio	Fan RPM	Service HP Rating (2.0 Service Factor)
1750	3.45	507	70
1750	4.10	427	70
1750	4.56	389	70
1750	5.11	342	60
1750	5.50	318	60
1750	6.12	286	53
1750	6.50	267	53
1750	7.33	239	47

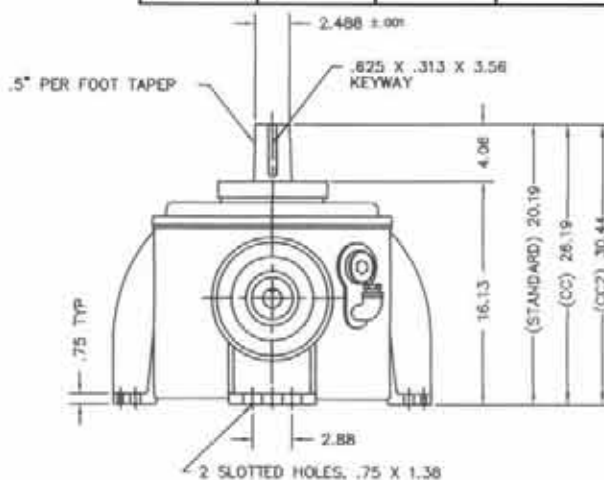
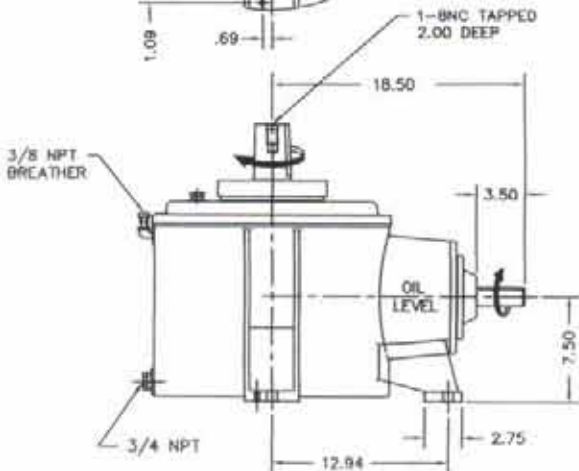

Model A27

Input RPM	Gear Ratio	Fan RPM	Service HP Rating (2.0 Service Factor)
1750	5.77	303	80
1750	7.71	227	75
1750	8.66	202	60
1750	9.83	178	40

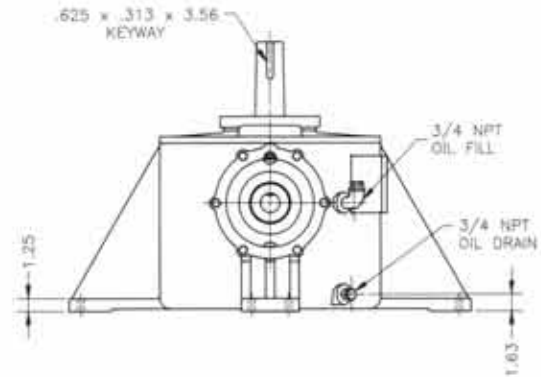
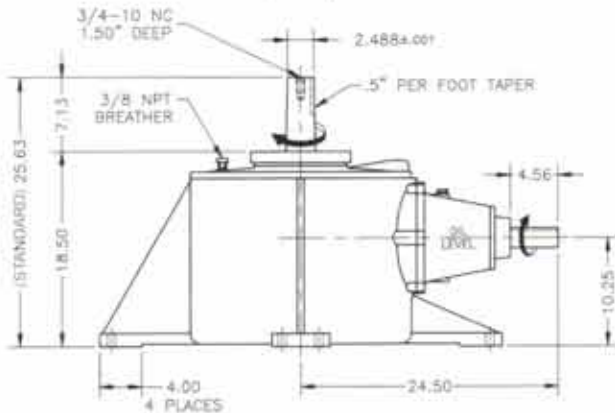
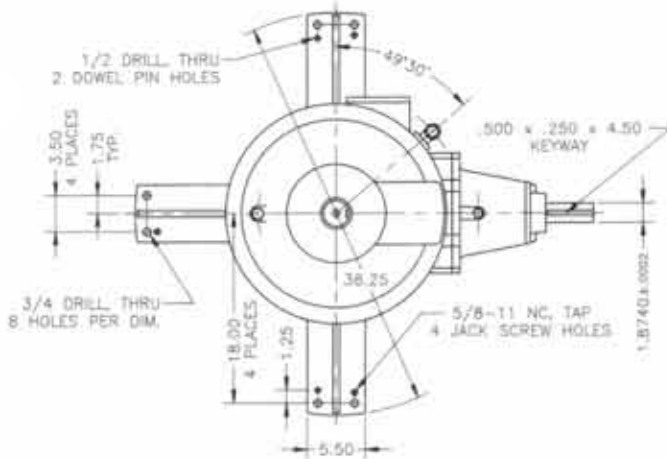

Tapered Output Shaft Information

All AMARILLO "A" Series right angle cooling tower drives will be furnished with the STANDARD output shaft noted in the drawings in this brochure. On occasion, the gear replaced may have a different output shaft than STANDARD as shown. Amarillo Gear Company can provide a matching output shaft when the following information (or shaft drawing) is provided. Please provide the information required below to confirm output shaft selection.

- Length of taper (D) _____
- Small end diameter (E1) _____
- Large end diameter (E2) _____
- Keyway size (F) _____
- Keyway parallel to centerline or taper _____
- Overall Height (C) _____

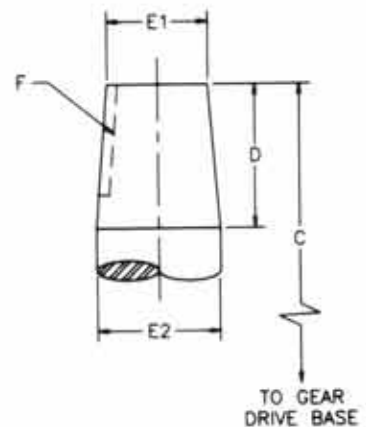

Weights and Shipping Dimensions

Amarillo Gear Company reserves the right to make design modifications to our gear drives that may change the given dimensions. The dimensions shown in this brochure may not exactly reflect the dimensions of gear drives currently being offered. Request a Certified Dimension Print for construction use.

Model	Net Weight (lbs)	Weight With Export Boxing (lbs)	Export Box Dimensions (LxWxH)(in)
A20	200	240	29 x 19 x 27
A22	440	500	36 x 23 x 34
A27	840	940	36 x 40 x 30
A32	1575	1720	55 x 36 x 40
A34	2225	2405	58 x 46 x 40
A36	2245	2425	58 x 46 x 40
A38	2300	2480	58 x 46 x 40

Model A32

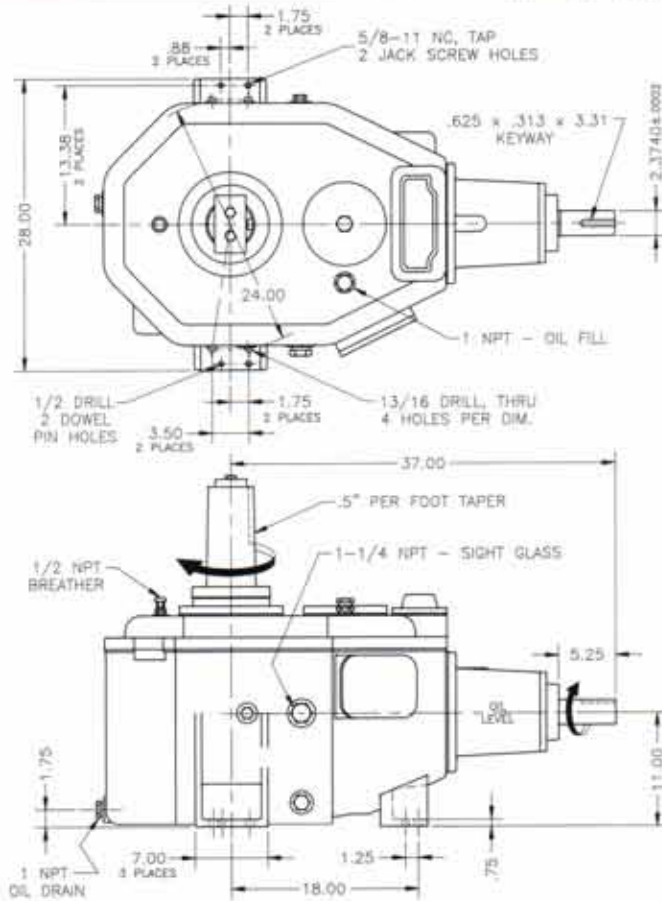

Input RPM	Gear Ratio	Fan RPM	Service HP Rating (2.0 Service Factor)
1750	6.47	270	160
1750	7.89	222	160
1750	8.80	199	160
1750	10.16	172	160
1750	11.18	157	160
1750	12.93	135	160

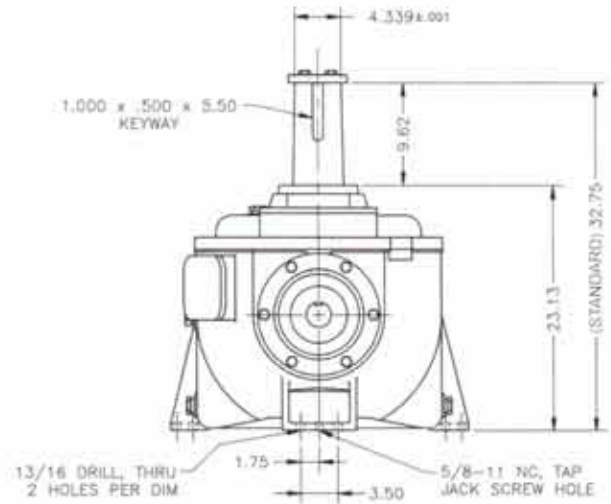

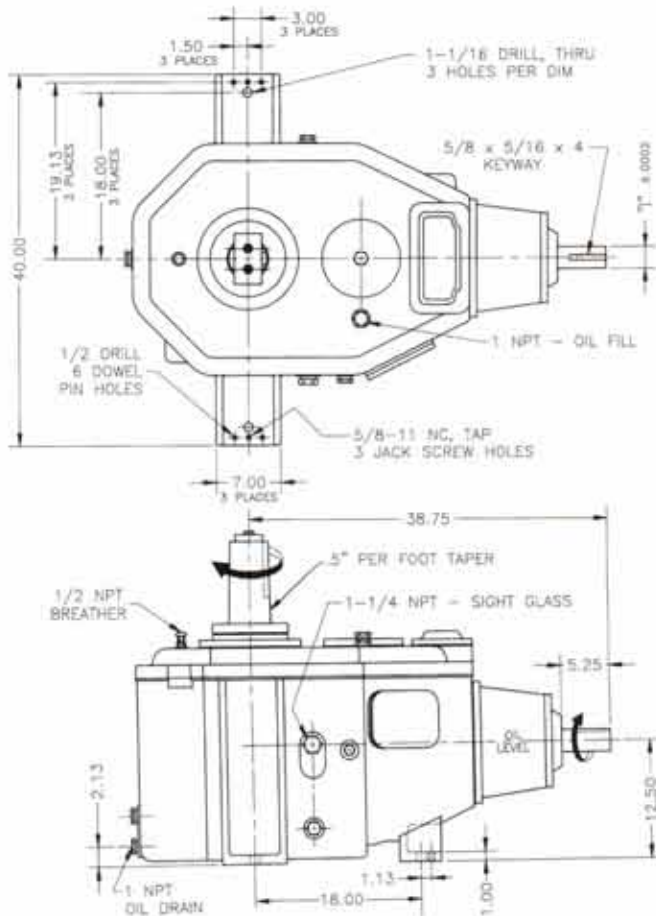

Model A34 — A36 — A38

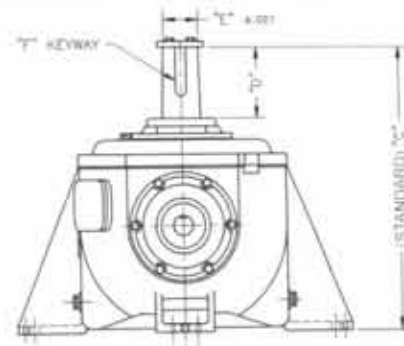

Model No.	Input RPM	Gear Ratio	Fan RPM	Service HP Rating (2.0 Service factor)
A34	1750	8.85	198	180
	1750	10.28	170	180
	1750	11.18	157	180
	1750	13.00	135	180
A36	1750	9.64	182	250
	1750	10.83	162	230
	1750	11.55	152	220
	1750	12.98	135	220
A38	1750	11.44	153	250
	1750	12.98	135	250

Model	"C"	"D"	"E"	"F" Keyway	"I"
A34	34.13	8.75	4.160	1/4 x 5/8 x 6	2.3750
A36	33.94	7.88	6.227	1/2 x 3/4 x 7	2.6250
A38	33.94	7.88	6.227	1/2 x 3/4 x 7	2.6250





Each Amarillo fan drive is the result of careful design and manufacturing technique. As with any precision machine component, proper selection, installation, maintenance and operating procedures are imperative for long life and trouble-free service. The following instructions are offered for selection of gear drives for usual applications. Our engineers will be pleased to assist when unusual conditions require special procedures.

Ratio

All ratios are reducing and defined as the ratio of input speed to output speed. Single and double reduction ratios shown are exact within $\pm 2\%$. Ratios shown in shaded portion of each table are normally available for expedited delivery. Check with the factory for availability and lead time of all model ratios not shaded.

Ratings

AGMA and CTI recommend a minimum service factor of 2.0 for gear drives in cooling tower fan service when driven by electric motors or steam turbines. All ratings are service ratings and include a 2.0 service factor. Ratings are listed for 1750 rpm motor speeds. Ratings for speeds less than 1750 rpm are proportional to the rating at 1750 rpm. Contact the factory for recommendations when the driver speed exceeds 1800 rpm.

Selection

The required ratio is established by dividing the input or driver speed by the output or fan speed. Select a model from the table that represents the closest desired reduction ratio with a service horsepower rating that meets or exceeds the full-load motor horsepower at 1750 rpm. The service horsepower ratings are listed directly to the right of the gear ratio for each model. When gear drives are to be selected using a service factor other than the listed, multiply the service horsepower rating from the table by the listed service factor to get the mechanical rating. The mechanical rating is then divided by the required service factor to obtain the new service horsepower rating at the required service factor. Note that both AGMA and CTI recommend a minimum service factor of 2.0 for gear drives in cooling tower fan service.

Limited Warranty

The Amarillo Right Angle Gear Drive is guaranteed against defects in workmanship and material for a period of one year after installation when operated under normal service at rated capacity. Within the above stated period, the manufacturer will replace the defective parts returned transportation prepaid. The buyer shall not be entitled to incidental or consequential damages, losses or expenses. The guarantee will not apply to repairs made outside the factory without the consent of the manufacturer or to drives that have been subject to abuse, accident, neglect, or improper installation. No warranty is made in regard to bearings, trade accessories, machinery, or other articles of merchandise not manufactured by us. **This warranty is expressly made in lieu of any warranties otherwise expressed or implied by law.**

Direction of Rotation

Normal rotation is both shafts clockwise as shown in the illustrations. Occasional use with both shafts rotating counterclockwise is permissible. Special bearing arrangements are used when the primary direction of rotation is counterclockwise and the gear drives should be ordered accordingly.



"A" Series Right Angle Gear Drives For Cooling Towers

The "A" Series right angle gear drives for cooling towers from AMARILLO GEAR are designed as direct replacements for the Marley® Cooling Tower line of right angle drives. Since there are no differences in the critical mounting dimensions, the "A" Series will make gear drive replacements easy. Gear housing foot patterns are identical, eliminating expensive tower gear drive support modifications. The input shaft diameters and keyways are the same, so existing couplings and drive shafts do not have to be replaced. All service ports are also easily accessible. Reduction ratios are within $\pm 2\%$ of the Marley® reduction ratios, eliminating the need to make costly fan pitch adjustments.

And as always, each AMARILLO GEAR "A" Series is designed and manufactured to the exacting quality you have come to expect and rely on. AMARILLO GEAR has been designing and manufacturing spiral bevel right angle gear drives since 1934, and the commitment to excellence continues today. One of many examples of this commitment to excellence is the availability of complete noise and vibration testing performed at up to 500 horsepower loading. Design features and ratings are in accordance with, or exceed, the minimum requirements of AGMA (American Gear Manufacturers Association) and CTI (Cooling Technology Institute) standards.

Housing and Castings

Gear housing and castings are designed to ensure that critical dimensions correspond to those of the counterpart Marley® model. Castings are rigidly designed and constructed to absorb internal and external loads with minimum deflection. Gear case and cover are manufactured to assure permanent alignment of bearings and gears under load. The sloped floor of the gear case adds rigidity and permits complete oil drainage. All casting materials are gray cast iron for effective damping of noise and vibration. All mating castings are sealed using "formed-in-place" gasket material that eliminates "weeping" associated with fiber-type gaskets.

Spiral Bevel Gears

Designed and manufactured by AMARILLO GEAR for fan drive service, all spiral bevel gears are precision machined from high grade alloy steel, case hardened and lapped in pairs, allowing for quiet and efficient operation.

Helical Gears

Helical gears are designed specifically for fan drive service and are precision machined from high grade alloy steel, case hardened and precision ground to provide low-noise, low vibration operation.

Bearings

All bearings are roller type, provided by major manufacturers. The fan shaft thrust bearing is designed to carry all loads imposed by the fan while maintaining 100,000 hours L₁₀ life. All bearings are sized to meet or exceed the minimum life requirements of AGMA and CTI.

Quiet Operation

Quiet operation of the Amarillo Fan Drives is achieved through careful design and controlled manufacturing methods of components. Our engineers understand all of the many parameters that affect gear noise and have applied the latest research to the design and manufacture of all components. Parameters that reduce gear noise are controlled during design, manufacturing and assembly to guarantee quiet operation. Rigid shafts and permanently aligned housings guarantee alignments of gears under load are maintained. Test results collected in our state-of-the-art test facility proves that our sound levels are the lowest available in the industry.

Shafting

All shafting is made from high alloy, fatigue resistant steel. Positioning of input and output shafts maintain the same dimensional locations as the corresponding Marley gear drive. Diameter and keyway of the input shaft remains unchanged. The output shaft is available in both the standard 1/2" per foot taper and special order dimensions. Note that the table entitled "Tapered Output Shaft Information" should be referenced to assure correct output dimensions before any order is placed. Surfaces for gears, bearings, and input coupling are precision ground.

Lubrication

Oversize slinger on the input shaft provides adequate lubrication in either direction or at half speed operation. Continuous circulation of oil to all bearings is assured by location of channels and baffles. A permanently mounted oil sight level gauge is provided on all double reduction units to provide direct visual determination of oil level.

Service Openings

Ports for oil fill, oil drain, inspection, and venting are easily accessible.

Shaft Seals

Both the input and output shaft openings have spring-loaded, single-lipped type seals to keep outside contamination from entering the gearbox. Plus, the output shaft has a labyrinth-type plate directly mounted to the shaft to triple protect the gearbox from contamination that might try to enter due to the natural effect of gravitation.

Optional Features

Special output shaft dimensions, backstops (anti-windmilling), oil level switch, oil heaters and thermostats, oil temperature switches, spot-face/drill and tap for vibration transducers, "low speed" option for single reduction gearboxes when motor input speeds drop below 450 rpm and other accessory items are available on special order.

Catalog ACT 2/09



Amarillo® Gear Company