



## AMARILLO GEAR COMPANY

Postal Address: Box 1789, Amarillo, Texas 79105

Plant Location: 2401 Sundown Lane, Amarillo, Texas 79118

T: 806-622-1273

FAX: 806-622-3258

www.amarillogear.com

e-mail: info@amarillogear.com

### OPERATION AND MAINTENANCE INSTRUCTIONS FOR AMARILLO "A" SERIES COOLING TOWER DRIVES



Each Amarillo Fan drive is the result of careful design and manufacturing techniques. As with any precision machine component, proper installation, maintenance and operating procedures are imperative for long life and trouble free service. The following instructions are offered to cover most conditions. Our engineers will be pleased to assist when unusual conditions require special procedures.

**INSTALLATION:** Make sure the gear drive is filled with the proper amount and type of lubricant. Normally, gear drives are shipped with the proper amount and type of lubricant installed. Install oil if drive is shipped without oil or add oil if spillage has occurred. The initial oil level should be to the middle of the oil level sight gauge and should be maintained so that the oil level is always visible in the sight gauge window when the unit is stationary and the oil is at ambient temperature.

Remove rust preventive from shaft extension and clean thoroughly. Install coupling halves. Couplings should be machined for a clearance fit. Hammering or mechanically forcing the coupling on the shaft can damage the bearings or disturb the setting of the gears and is not permissible. Interference fits are permissible if the coupling half can be heated for installation and fitted without hammering or mechanically forcing on the gear drive shaft. Check runout of aligning surfaces on both coupling halves before installing connecting members.

Level gear drive. If shimming is required, take precautions to prevent distortion of the housing. Align driver with gear drive to obtain parallel and angular alignment. Recheck alignment after two weeks of operation.

On "Wet Tower" installation, it is recommended that the breather plug located on the top of the gear housing be removed and piped in from outside the stack, away from the direct stream of moist air. Installation of piping to the other service openings will expedite routine maintenance and can be installed if desired. Service openings include oil fill and oil drain. Use a suitable sealer for all pipe joints and coat all exposed threads to prevent corrosion. Check all external fasteners for tightness.

**OPERATION:** No special break-in procedures are necessary except as noted under lubrication.

Each unit is subjected to a running test at the factory to assure smooth and quiet operation. Excessive noise or vibration at initial operation is an indication of one or a combination of the following: (1) Misalignment (2) Imbalance of fan or other rotating parts (3) Improperly adjusted fan blades (4) Torsional vibration (5) Unstable mounting. If noise or vibration persists, shut the unit down and correct the fault before further operation.

On installations with **two speed motors**, allow a suitable time delay before switching from high speed to low speed. The fan must be at, or below, the slow speed before energizing the slow speed winding.

When reversing directions of rotation, allow the fan to come to a complete stop before restarting the motor.

On installations with **variable speed motors**, do not operate standard gear drives below 450 RPM motor speed. For operation at motor speeds less than 450 RPM, single reduction fan drives require Amarillo Gear's exclusive "**Low Speed**" option, and double reduction fan drives require an **electric** oil pump for proper lubrication. The addition of these options allows operation with no minimum speed restrictions.

On most fan drive systems, it is not uncommon for one or more resonant speeds to exist between 0 and 1800 RPM. Continued operation at a resonant speed condition will result in torsional vibration which can be damaging to all components of the system. The most common indicator of torsional vibration is an unusual rumbling or grinding noise from the gear drive at a sharply defined speed. The noise will disappear when the speed is increased or decreased. The noise is not indicative of a defect but results when the vibratory torque exceeds the drive torque causing the gear teeth to separate and clash together very rapidly. On **variable speed** applications, operation within  $\pm 10\%$  of a resonant speed should be avoided and the transition through a resonant speed range should be swift.

**MAINTENANCE:** Check oil level weekly with each unit stopped. Add oil if level is below oil level indicator on the double reduction, and if it is below the oil fill outlet on the single reduction.

Daily visual inspections and observation for oil leaks and unusual noises and vibrations are recommended. If any of these occurs, the unit should be shut down and the cause found and corrected.

Periodic checks should be made of the alignments of all components of the system. Also, all external fasteners should be checked for tightness.

Special precautions are necessary during periods of inactivity in excess of one week. When the internal parts are not continually bathed by the lubricant as during operation, the gear drive is particularly vulnerable to attacks by rust and corrosion. For best results, let the drive cool for approximately four hours after shutdown, start the fan and let run for approximately five minutes. This will coat the internal parts of the drive with cool oil. Thereafter, run the fan for five minutes once a week throughout the shutdown period to maintain the oil film on the internal parts of the gear drive.

If the drive is to be inactive for a prolonged period, it is recommended that the unit be completely filled with oil. This can be accomplished by filling through the air breather port. Cover the drive with a tarpaulin or other protective covering. Drain excess oil before returning the gear drive to service.

By following the above procedures, each Amarillo Fan Drive will provide years of useful service. In the event repairs are necessary, all parts are stocked at the factory and normally can be shipped within twenty-four hours after receipt of an order. Prompt factory re-build service is also available.

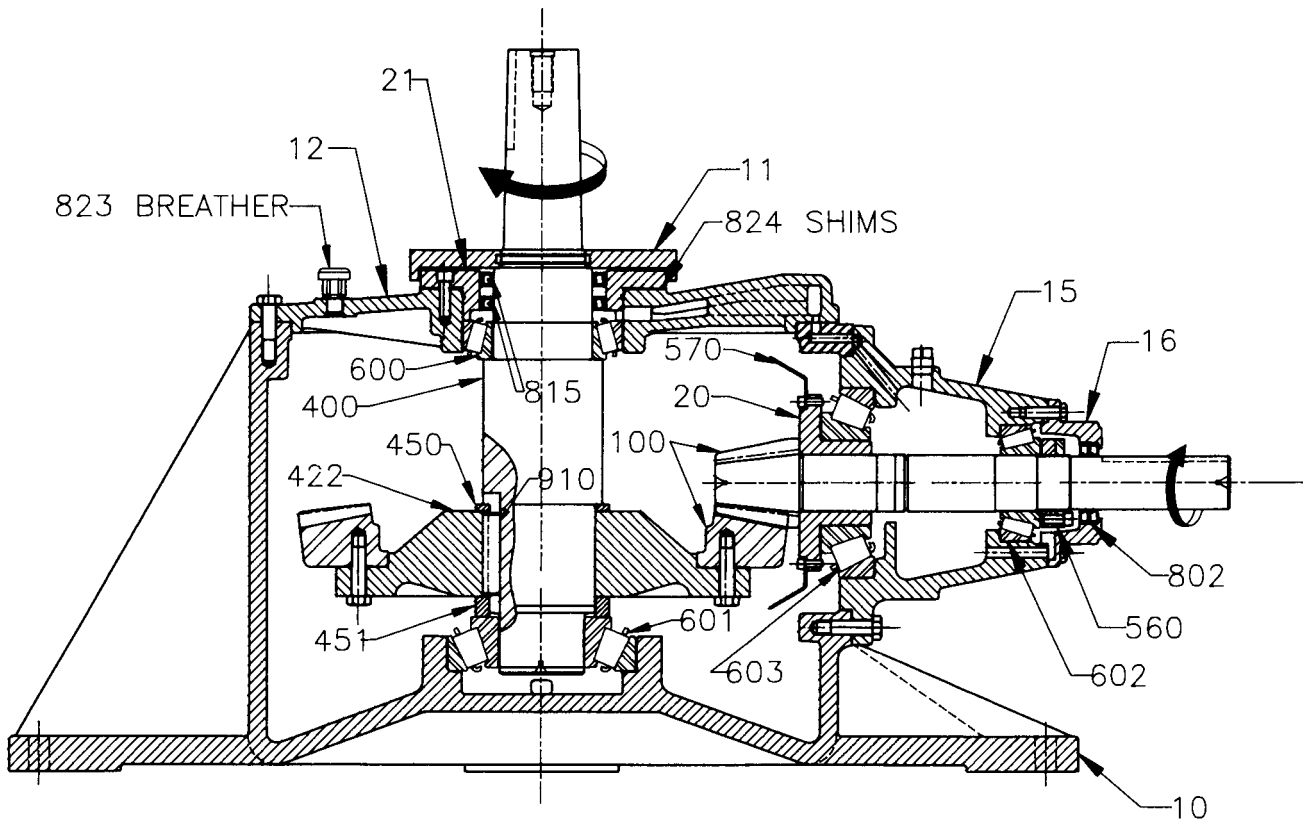
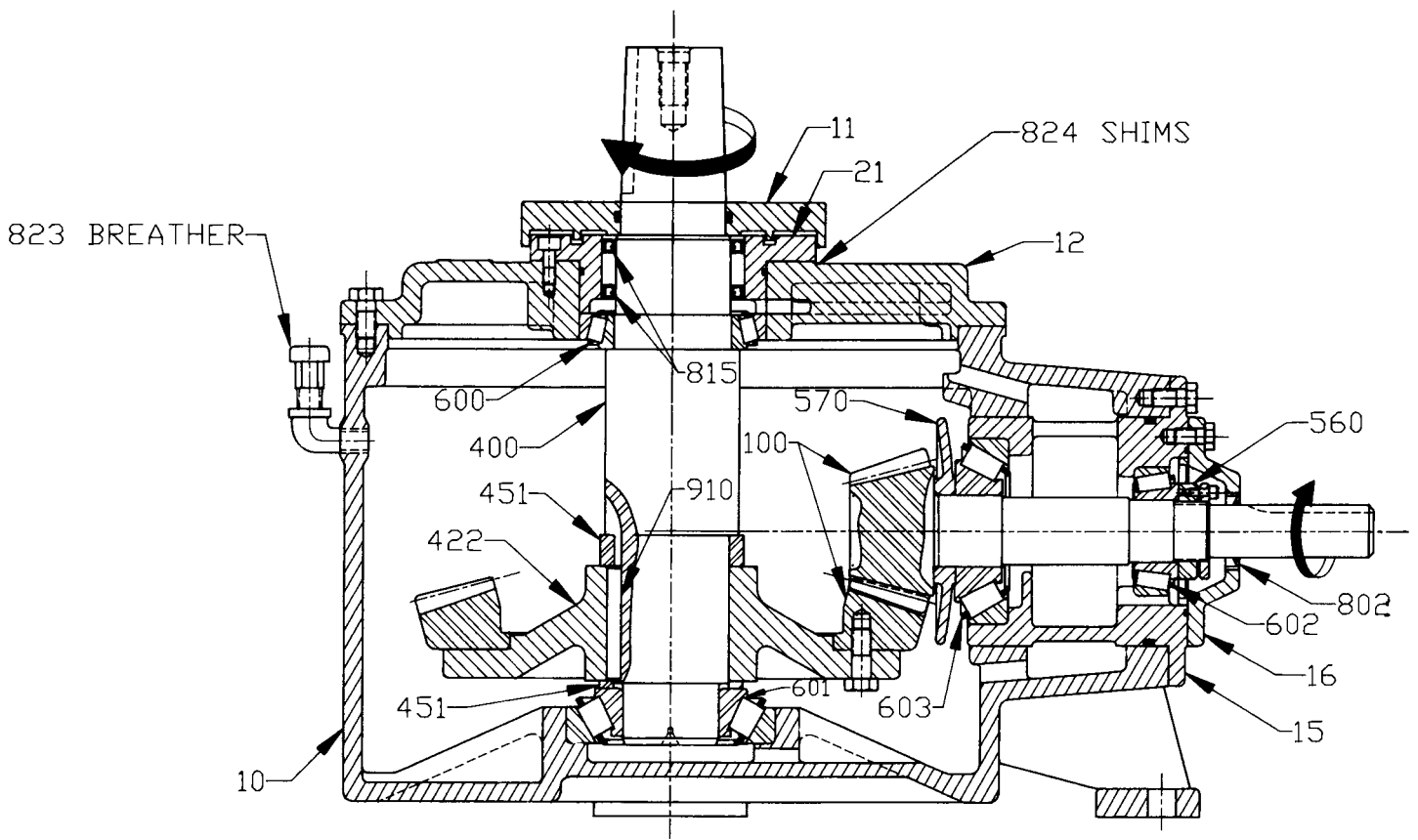

# DOUBLE REDUCTION

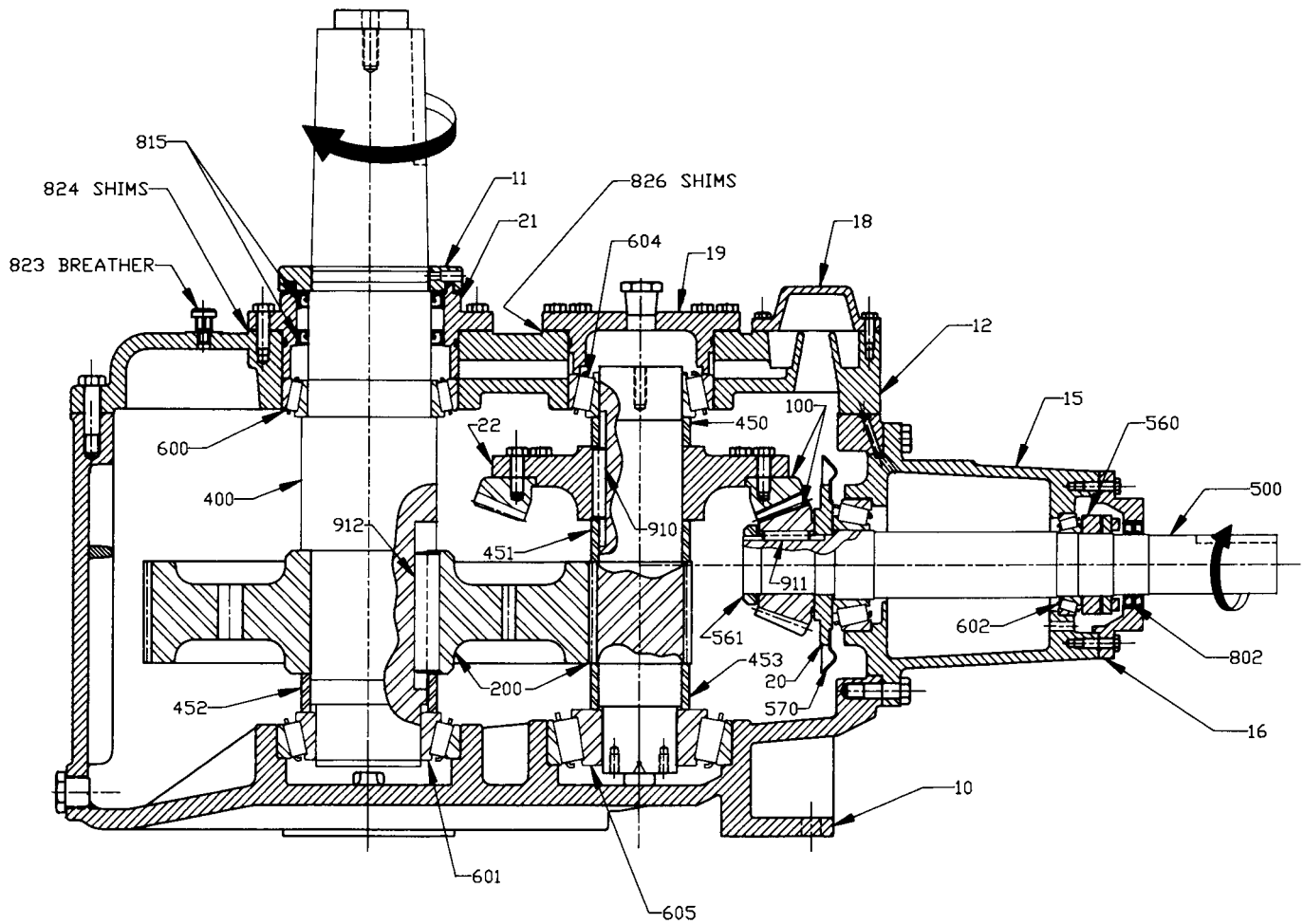

MODEL A32, A34, A36 & A38

REF NO.	PART NAME	PART NUMBER			
		MODEL A32	MODEL A34	MODEL A36	MODEL A38
10	(5) Gear Case	MD3-10	MD4-10	MD4-10	MD4-10
11	Upper Seal Plate	MD3-11	D4-11	34084	34084
12	(5) Cover	MD3-12	MD4-12	MD4-12	MD4-12
15	Horizontal Carrier	MD3-15	D4-13	D4-13	D4-13
16	Horizontal Seal Plate	D3-16A	D5-16A	D5-16A	D5-16A
18	Oil Pocket Cover Plate	D2-18	D4-18	D4-18	D4-18
19	Upper Brg. Cover (Interm. Shaft)	D3-19	D4-19	D4-19M	D4-19M
20	Oil Slinger Plate	33018	D4-20	D4-20	D4-20
21	Vertical Seal Carrier	D3-21	D4-21	34085	34085
22	(3) Gear Mount	D3-22	D4-22	D4-22	D4-22
--	Inspection Plate	L18B	L18B	L18B	L18B
100	*Spiral Bevel Gear Set	See Note (2)	See Note (2)	See Note (2)	See Note (2)
200	*Helical Gear Set	200-A32	200-A34	200-A36	200-A38
400	Output Shaft	37008	38006	34083	34083
450	Above Gear Spacer (Interm. Shaft)	450-A32	450-A34	450-A36	450-A38
451	Between Gear Spacer (Interm. Shaft)	451-A32	451-A34	451-A36	451-A38
452	Below Gear Spacer (Output Shaft)	452-A32	452-A34	452-A36	452-A38
453	Below Gear Spacer (Interm. Shaft)	453-A32	453-A34	453-A36	453-A38
--	*Between Helical Spacer	N/A	N/A	XF-A36	XF-A38
500	(4) Horizontal Shaft	500-A32	500-A34	500-A36	500-A38
560	Horizontal Locknut Set	5237	6217	6217	6217
570	Oil Slinger	32025	34022	34022	34022
600	*Upper Brg. (Output Shaft)	600-A32	600-A34	600-A36	600-A38
601	*Lower Brg. (Output Shaft)	601-A32	601-A34	601-A36	601-A38
602	*Outer Brg. (Horiz. Shaft)	602-A32	602-A34	602-A36	602-A38
603	*Inner Brg. (Horiz. Shaft)	603-A32	603-A34	603-A36	603-A38
604	*Upper Brg. (Interm. Shaft)	604-A32	604-A34	604-A36	604-A38
605	*Lower Brg. (Interm. Shaft)	605-A32	605-A34	605-A36	605-A38
802	*Horizontal Seal Set	802-A32	802-A34	802-A36	802-A38
815	*Vertical Seal Set	815-A32	815-A34	815-A36	815-A38
823	Breather Plug	823	823	823	823
824	*Brg. Shims (Output Shaft)	824-A32	824-A34	824-A36	824-A38
825	*Gasket Set	825-A32	825-A34	825-A36	825-A38
826	*Brg. Shims (Interm. Shaft)	826-A32	826-A34	826-A36	826-A38
--	*Upper Brg. Cover O-Ring	M AS255	M AS258V	M AS258V	M AS258V
--	*Vertical Seal Carrier O-Ring	M AS364	M AS369	M AS267V	M AS267V
910	Gear Key (Interm. Shaft)	910-A32	910-A34	910-A36	910-A38
911	Gear Key (Horizontal Shaft)	911-A32	911-A34	911-A36	911-A38
912	Gear Key (Output Shaft)	912-A32	912-A34	912-A36	912-A38
913	(4) Oil Slinger Key	913-A32	913-A34	913-A36	913-A38
--	Oil Sight Gauge	P1022-6	P1022-6	P1022-6	P1022-6
--	Hub Retainer Plate	37009	37009	34088	34088
--	Brg. Adjustment Plate	N/A	N/A	34086	34086
--	Snap Ring	N/A	N/A	3100-650	3100-650

\*RECOMMENDED SPARE PARTS

- 1) Specify Serial Number when ordering repair parts.
- 2) Spiral Bevel Gear Sets are specified by Model Number and Ratio.
- 3) Vertical Gear Mounts are not used for all ratios. The Gear Mount and corresponding Vertical Shaft should be ordered assembled as a set.
- 4) Not applicable to all ratios; consult factory.
- 5) Gear Case and Cover must be purchased as a unit.

# SINGLE REDUCTION

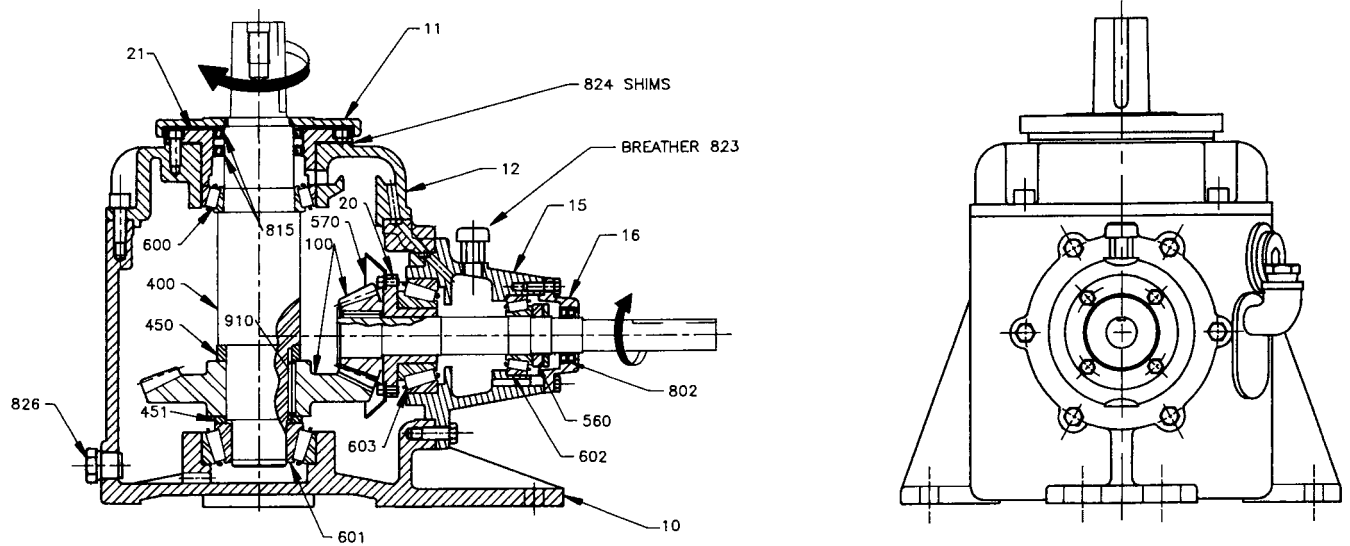

## MODEL A20

REF NO.	PART NAME	PART NUMBER		
		MODEL A20	MODEL A22	MODEL A27
10	Gear Case	MF2-10	MF3-10	MF4-10
11	Upper Seal Plate	MF2-11	MF3-11	MF4-11
12	Vertical Carrier	F2-12	MF3-12	MF4-12
15	Horizontal Carrier	F2-15	MF3-15	F5-15
16	Horizontal Seal Plate	F2-16A	MF3-16	F6-16A
18	Inspection Plate	N/A	N/A	E18
20	Bearing Bushing	F2-20	N/A	F5-20
21	Vert. Seal Carrier	MF2-21	MF3-21	MF4-21
400	Vertical Shaft	29006	27008	28009
422	Gear Mount (See Note 3)	N/A	F4-22	L22
450	Above Gear Spacer	450-A20	450-A22	450-A27
451	Under Gear Spacer	451-A20	451-A22	451-A27
560	Horiz. Locknut Set	1231	2230	3268
570	Oil Slinger	22008	MF3-20	24008
600	*Vertical Upper Bearing	600-A20	600-A22	600-A27
601	*Vertical Lower Bearing	601-A20	601-A22	601-A27
602	*Horiz. Outer Bearing	602-A20	602-A22	602-A27
603	*Horiz. Inner Bearing	603-A20	603-A22	603-A27
802	*Horizontal Seal Set	802-A20	802-A22	802-A27
815	*Vertical Seal Set	815-A20	815-A22	815-A27
823	Breather Plug	823	823	823
824	*Bearing Shim Set	824-A20	824-A22	824-A27
825	*Gasket Set(Not Shown)	825-A20	N/A	825-A27
826	Oil Drain Plug	826-A20	826-A22	826-A27
910	Gear Key	910-A20	910-A22	910-A27
100	*Spiral Bevel Gear Set	See Note (2)	See Note (2)	See Note (2)
--	*Horizontal Shim Set	N/A	SMH-A22	N/A
--	*Upper Seal Plate O-Ring	M AS140	M AS334	M AS337
--	*Vert. Seal Carrier O-Ring	N/A	M AS247	M AS161
--	*Oil Seal Plate O-Ring	N/A	M AS155	N/A
--	*Horiz. Carrier O-Ring	N/A	M AS358	N/A

- 1) Specify Serial Number when ordering repair parts.
- 2) Spiral Bevel Gear Sets are specified by Model Number and Ratio.
- 3) Vertical Gear Mounts are not used for all ratios. Gear Mount and corresponding Vertical Shaft should be ordered assembled as a set.

\*RECOMMENDED SPARE PARTS

**\*RECOMMENDED MINERAL OILS**

AMBIENT TEMPERATURE AT GEAR DRIVE	20° F to 120° F (-7° C to 49° C)
AGMA LUBRICANT NUMBER	5
ISO Grade	220
Atlantic Richfield Co.	Duro 220
Chevron Oil Co.	Machine Oil A W 220
Cities Service Oil Co.	Citigo Pacemaker 220
Conoco	Hydroclear Multipurpose R & O Oil 220
Exxon Company	Teresstic 220
Gulf Oil Corp.	Harmony 220
Mobil Oil Corp.	DTE Oil BB
Pennzoil	Pennzbell TO 220
Phillips Petroleum Co.	Magnus 220
Shell Oil Co.	Morlina 220
Sun Oil Co.	Sunvis 9220
Texaco Inc.	Regal 220 R & O, Code 1531
Total	Carter 220

\*LIST OF BRAND NAMES IS FOR PURPOSE OF IDENTIFYING TYPES AND IS NOT TO BE CONSTRUED AS EXCLUSIVE RECOMMENDATIONS.

**\*RECOMMENDED SYNTHETIC LUBRICANTS**

AMBIENT TEMPERATURE AT GEAR DRIVE	-20° F to 150° F (-29° C to 66° C)
AGMA LUBRICANT NUMBER	5S
ISO GRADE	220
Chevron Oil Co.	Clarity 220 Synthetic
Conoco	Syncon 220 - R & O Oil
Mobil	SHC 630

**LUBRICATION:** Use only Rust and Oxidation Inhibited Gear Oils in accordance with AGMA (American Gear Manufacturers Association), Standard 9005-E02 (or most recent edition of the standard). For general operating conditions, use a lubricant having an AGMA lubricant number of 5. Gear oils containing Extreme Pressure (EP) additives are not recommended.

If the gear drive is started when the ambient temperature is below 20° F (-7° C), use a lube oil heater or a recommended synthetic oil. Lube oil heaters and synthetic oil are extra cost accessories that can be ordered with new gear drives or installed in the field.

**SYNTHETIC LUBRICANTS:** Synthetic lubricants offer advantages of extended service life, a broader operational temperature range, reduced friction, and the ability to maintain a higher film strength which can extend the service life of the gear drive. When the operating temperature exceeds 180° F (82° C) or the gear drive is started when the ambient temperature is below 20° F (-7° C), a synthetic lubricant is recommended. Synthetic lubricants can be made of various base stocks which are incompatible with certain gear drive components; therefore, any synthetic lubricant not listed in this bulletin should be approved by Amarillo Gear Company. Do not use synthetic lubricants made from ester base stocks. Change intervals for synthetic lubricants should not be extended beyond the change interval for mineral oils without a comprehensive monitoring program.

**CHANGE INTERVAL:** The original oil should be replaced after 500 hours of operation or four weeks, whichever comes first. It is recommended that the oil be drained when it is at or near operating temperature. Refill the drive with the recommended type and amount of lubricant.

Normally the oil should be changed every 2500 hours or every six months, whichever comes first. Shorter change intervals of two to three months may be required if the gear drive is subjected to unusual operating conditions such as very moist atmosphere, rapid temperature change, consistent high operating temperature or any conditions that tend to contaminate the oil or promote the formulation of sludge and deposits inside the gear case.

The vertical and horizontal shafts are equipped with grease lubricated dual seals. Relubrication is not required.

**OIL CAPACITY**

**SINGLE REDUCTION DRIVES**

MODEL	GALLONS	LITERS
A20	2	7.5
A22	4	15
A27	10	38

**DOUBLE REDUCTION DRIVES**

MODEL	GALLONS	LITERS
A32	17	64
A34	21	79
A36	21	79
A38	21	79